

Date _____	Train ID _____		
Critical orifice size _____	Critical vacuum _____		
		<u>Pretest</u>	<u>Post-test</u>
Soap bubble meter volume, cc		_____	_____
V_{sb}	$m^3 (ft^3)$	_____	_____
Time, θ	sec	_____	_____
	min	_____	_____
Barometric pressure, P_{bar}	mm Hg (in. Hg)	_____	_____
Ambient temperature, t_{amb}	$^{\circ}C (^{\circ}F)$	_____	_____
Inlet vacuum, P_c	mm Hg (in. Hg)	_____	_____
Outlet vacuum	mm Hg (in. Hg)	_____	_____
$V_{sb(std)}$	$m^3 (ft^3)$	_____	_____
Flow rate, Q_{std}	$\frac{m^3}{min} \left(\frac{ft^3}{min} \right)$	_____	_____

Figure 6-4. Critical Orifice Calibration Data Sheet.

METHOD 6A—DETERMINATION OF SULFUR DIOXIDE, MOISTURE, AND CARBON DIOXIDE FROM FOSSIL FUEL COMBUSTION SOURCES

NOTE: This method does not include all of the specifications (e.g., equipment and supplies) and procedures (e.g., sampling and analytical) essential to its performance. Some material is incorporated by reference from

other methods in this part. Therefore, to obtain reliable results, persons using this method should have a thorough knowledge of at least the following additional test methods: Method 1, Method 2, Method 3, Method 5, Method 6, and Method 19.

1.0 Scope and Application

1.1 Analytes.

Analyte	CAS No.	Sensitivity
SO ₂	7449-09-05	3.4 mg SO ₂ /m ³ (2.12 × 10 ⁻⁷ lb/ft ³)
CO ₂	124-38-9	N/A
H ₂ O	7732-18-5	N/A

1.2 **Applicability.** This method is applicable for the determination of sulfur dioxide (SO₂) emissions from fossil fuel combustion sources in terms of concentration (mg/dscm or lb/dscf) and in terms of emission rate (ng/J or lb/10⁶ Btu) and for the determination of carbon dioxide (CO₂) concentration (percent). Moisture content (percent), if desired, may also be determined by this method.

1.3 **Data Quality Objectives.** Adherence to the requirements of this method will enhance the quality of the data obtained from air pollutant sampling methods.

2.0 Summary of Method

2.1 A gas sample is extracted from a sampling point in the stack. The SO₂ and the sulfur trioxide, including those fractions in any sulfur acid mist, are separated. The SO₂ fraction is measured by the barium-thorin titration method. Moisture and CO₂ fractions are collected in the same sampling train, and are determined gravimetrically.

3.0 Definitions. [Reserved]

4.0 Interferences

Same as Method 6, Section 4.0.

5.0 Safety

5.1 **Disclaimer.** This method may involve hazardous materials, operations, and equipment. This test method may not address all of the safety problems associated with its use. It is the responsibility of the user to establish appropriate safety and health practices and determine the applicability of regulatory limitations prior to performing this test method.

5.2 **Corrosive reagents.** Same as Method 6, Section 5.2.

6.0 Equipment and Supplies

6.1 **Sample Collection.** Same as Method 6, Section 6.1, with the exception of the following:

6.1.1 **Sampling Train.** A schematic of the sampling train used in this method is shown in Figure 6A-1.

6.1.1.1 **Impingers and Bubblers.** Two 30=ml midget impingers with a 1=mm restricted tip and two 30=ml midget bubblers with unrestricted tips. Other types of impingers and bubblers (e.g., Mae West for SO₂ collection and rigid cylinders containing Drierite for moisture absorbers), may be used with proper attention to reagent volumes and levels, subject to the approval of the Administrator.

6.1.1.2 **CO₂ Absorber.** A sealable rigid cylinder or bottle with an inside diameter between 30 and 90 mm, a length between 125 and 250 mm, and appropriate connections at both ends. The filter may be a separate heated unit or may be within the heated portion of the probe. If the filter is within the sampling probe, the filter should not be within 15 cm of the probe inlet or any unheated section of the probe, such as the connection to the first bubbler. The probe and filter should be heated to at least 20 °C (68 °F) above the source temperature, but not greater than 120 °C (248 °F). The filter temperature (i.e., the sample gas temperature) should be monitored to assure the desired temperature is maintained. A heated Teflon connector may be used to connect the filter holder or probe to the first impinger.

NOTE: For applications downstream of wet scrubbers, a heated out-of-stack filter (either borosilicate glass wool or glass fiber mat) is necessary.

6.2 **Sample Recovery.** Same as Method 6, Section 6.2.

6.3 **Sample Analysis.** Same as Method 6, Section 6.3, with the addition of a balance to measure within 0.05 g.

7.0 Reagents and Standards

NOTE: Unless otherwise indicated, all reagents must conform to the specifications established by the Committee on Analytical Reagents of the American Chemical Society. Where such specifications are not available, use the best available grade.

7.1 **Sample Collection.** Same as Method 6, Section 7.1, with the addition of the following:

7.1.1 **Drierite.** Anhydrous calcium sulfate (CaSO₄) desiccant, 8 mesh, indicating type is recommended.

NOTE: Do not use silica gel or similar desiccant in this application.

7.1.2 **CO₂ Absorbing Material.** Ascarite II. Sodium hydroxide-coated silica, 8- to 20-mesh.

7.2 **Sample Recovery and Analysis.** Same as Method 6, Sections 7.2 and 7.3, respectively.

8.0 Sample Collection, Preservation, Transport, and Storage

8.1 **Preparation of Sampling Train.**

8.1.1 **Measure** 15 ml of 80 percent isopropanol into the first midget bubbler and 15 ml of 3 percent hydrogen peroxide into

each of the two midjet impingers (the second and third vessels in the train) as described in Method 6, Section 8.1. Insert the glass wool into the top of the isopropanol bubbler as shown in Figure 6A-1. Place about 25 g of Drierite into the second midjet bubbler (the fourth vessel in the train). Clean the outside of the bubblers and impingers and allow the vessels to reach room temperature. Weigh the four vessels simultaneously to the nearest 0.1 g, and record this initial weight (m_{wi}).

8.1.2 With one end of the CO₂ absorber sealed, place glass wool into the cylinder to a depth of about 1 cm (0.5 in.). Place about 150 g of CO₂ absorbing material in the cylinder on top of the glass wool, and fill the remaining space in the cylinder with glass wool. Assemble the cylinder as shown in Figure 6A-2. With the cylinder in a horizontal position, rotate it around the horizontal axis. The CO₂ absorbing material should remain in position during the rotation, and no open spaces or channels should be formed. If necessary, pack more glass wool into the cylinder to make the CO₂ absorbing material stable. Clean the outside of the cylinder of loose dirt and moisture and allow the cylinder to reach room temperature. Weigh the cylinder to the nearest 0.1 g, and record this initial weight (m_{ai}).

8.1.3 Assemble the train as shown in Figure 6A-1. Adjust the probe heater to a temperature sufficient to prevent condensation (see NOTE in Section 6.1). Place crushed ice and water around the impingers and bubblers. Mount the CO₂ absorber outside the water bath in a vertical flow position with the sample gas inlet at the bottom. Flexible tubing (e.g., Tygon) may be used to connect the last SO₂ absorbing impinger to the moisture absorber and to connect the moisture absorber to the CO₂ absorber. A second, smaller CO₂ absorber containing Ascarite II may be added in-line downstream of the primary CO₂ absorber as a breakthrough indicator. Ascarite II turns white when CO₂ is absorbed.

8.2 Sampling Train Leak-Check Procedure and Sample Collection. Same as Method 6, Sections 8.2 and 8.3, respectively.

8.3 Sample Recovery.

8.3.1 Moisture Measurement. Disconnect the isopropanol bubbler, the SO₂ impingers, and the moisture absorber from the sample train. Allow about 10 minutes for them to reach room temperature, clean the outside of loose dirt and moisture, and weigh them simultaneously in the same manner as in Section 8.1. Record this final weight (m_{wf}).

8.3.2 Peroxide Solution. Discard the contents of the isopropanol bubbler and pour the contents of the midjet impingers into a leak-free polyethylene bottle for shipping. Rinse the two midjet impingers and connecting tubes with water, and add the washing to the same storage container.

8.3.3 CO₂ Absorber. Allow the CO₂ absorber to warm to room temperature (about 10 minutes), clean the outside of loose dirt and moisture, and weigh to the nearest 0.1 g in the same manner as in Section 8.1. Record this final weight (m_{af}). Discard used Ascarite II material.

9.0 Quality Control

Same as Method 6, Section 9.0.

10.0 Calibration and Standardization

Same as Method 6, Section 10.0.

11.0 Analytical Procedure

11.1 Sample Analysis. The sample analysis procedure for SO₂ is the same as that specified in Method 6, Section 11.0.

11.2 Quality Assurance (QA) Audit Samples. Analysis of QA audit samples is required only when this method is used for compliance determinations. Obtain an audit sample set as directed in Section 7.3.6 of Method 6. Analyze the audit samples, and report the results as directed in Section 11.3 of Method 6. Acceptance criteria for the audit results are the same as those in Method 6.

12.0 Data Analysis and Calculations

Same as Method 6, Section 12.0, with the addition of the following:

12.1 Nomenclature.

C_w =Concentration of moisture, percent.
 C_{CO_2} =Concentration of CO₂, dry basis, percent.
 E_{SO_2} =Emission rate of SO₂, ng/J (lb/10⁶ Btu).
 F_c =Carbon F-factor from Method 19 for the fuel burned, dscm/J (dscf/10⁶ Btu).
 m_{wi} =Initial weight of impingers, bubblers, and moisture absorber, g.
 m_{wf} =Final weight of impingers, bubblers, and moisture absorber, g.
 m_{ai} =Initial weight of CO₂ absorber, g.
 m_{af} =Final weight of CO₂ absorber, g.
 m_{SO_2} =Mass of SO₂ collected, mg.
 $V_{CO_2(std)}$ =Equivalent volume of CO₂ collected at standard conditions, dscm (dscf).
 $V_{w(std)}$ =Equivalent volume of moisture collected at standard conditions, scm (scf).

12.2 CO₂ Volume Collected, Corrected to Standard Conditions.

$$V_{CO_2(std)} = K_3 (m_{af} - m_{ai}) \quad \text{Eq. 6A-1}$$

Where:

K_3 =Equivalent volume of gaseous CO₂ at standard conditions, 5.467×10^{-4} dscm/g (1.930×10^{-2} dscf/g).

12.3 Moisture Volume Collected, Corrected to Standard Conditions.

$$V_{w(std)} = K_4 (m_{wf} - m_{wi}) \quad \text{Eq. 6A-2}$$

Where:

K_4 =Equivalent volume of water vapor at standard conditions, 1.336×10^{-3} scm/g (4.717×10^{-2} scf/g).

12.4 SO₂ Concentration.

$$C_{\text{SO}_2} = \frac{K_2 N (V_t - V_{\text{tb}}) (V_{\text{soln}} / V_a)}{V_{\text{m(std)}} + V_{\text{CO}_2(\text{std})}} \quad \text{Eq. 6A-3}$$

Where:

K_2 =32.03 mg SO₂/meq. SO₂ (7.061×10^{-5} lb SO₂/meq. SO₂)

12.5 CO₂ Concentration.

$$C_{\text{CO}_2} = \frac{V_{\text{CO}_2(\text{std})}}{V_{\text{m(std)}} + V_{\text{CO}_2(\text{std})}} \quad \text{Eq. 6A-4}$$

12.6 Moisture Concentration.

$$C_w = \frac{V_{\text{w(std)}}}{V_{\text{m(std)}} + V_{\text{w(std)}} + V_{\text{CO}_2(\text{std})}} \quad \text{Eq. 6A-5}$$

13.0 Method Performance

13.1 Range and Precision. The minimum detectable limit and the upper limit for the measurement of SO₂ are the same as for Method 6. For a 20-liter sample, this method has a precision of ± 0.5 percent CO₂ for concentrations between 2.5 and 25 percent CO₂ and ± 1.0 percent moisture for moisture concentrations greater than 5 percent.

14.0 Pollution Prevention [Reserved]

15.0 Waste Management. [Reserved]

16.0 Alternative Methods

If the only emission measurement desired is in terms of emission rate of SO₂ (ng/J or lb/10⁶ Btu), an abbreviated procedure may be used. The differences between the above procedure and the abbreviated procedure are described below.

16.1 Sampling Train. The sampling train is the same as that shown in Figure 6A-1 and

as described in Section 6.1, except that the dry gas meter is not needed.

16.2 Preparation of the Sampling Train. Follow the same procedure as in Section 8.1, except do not weigh the isopropanol bubbler, the SO₂ absorbing impingers, or the moisture absorber.

16.3 Sampling Train Leak-Check Procedure and Sample Collection. Leak-check and operate the sampling train as described in Section 8.2, except that dry gas meter readings, barometric pressure, and dry gas meter temperatures need not be recorded during sampling.

16.4 Sample Recovery. Follow the procedure in Section 8.3, except do not weigh the isopropanol bubbler, the SO₂ absorbing impingers, or the moisture absorber.

16.5 Sample Analysis. Analysis of the peroxide solution and QA audit samples is the same as that described in Sections 11.1 and 11.2, respectively.

16.6 Calculations.

16.6.1 SO₂ Collected.

$$m_{\text{SO}_2} = K_2 N (V_t - V_{\text{tb}}) (V_{\text{soln}} / V_a) \quad \text{Eq. 6A-6}$$

Environmental Protection Agency

Pt. 60, App. A-4, Meth. 6A

Where:

$K_2=32.03 \text{ mg SO}_2/\text{meq. SO}_2$

$K_2=7.061 \times 10^{-5} \text{ lb SO}_2/\text{meq. SO}_2$

16.6.2 Sulfur Dioxide Emission Rate.

$$E_{\text{SO}_2} = K_5 F_c m_{\text{SO}_2} / (m_{\text{af}} - m_{\text{ai}}) \quad \text{Eq. 6A-7}$$

Where:

$K_5=1.829 \times 10^9 \text{ mg/dscm}$

$K_2=0.1142 \text{ lb/dscf}$

2. Whittle, Richard N. and P.R. Westlin. Air Pollution Test Report: Development and Evaluation of an Intermittent Integrated SO₂/CO₂ Emission Sampling Procedure. Environmental Protection Agency, Emission Standard and Engineering Division, Emission Measurement Branch. Research Triangle Park, NC. December 1979. 14 pp.

17.0 References

Same as Method 6, Section 17.0, References 1 through 8, with the addition of the following:

1. Stanley, Jon and P.R. Westlin. An Alternate Method for Stack Gas Moisture Determination. Source Evaluation Society Newsletter. 3(4). November 1978.

18.0 Tables, Diagrams, Flowcharts, and Validation Data

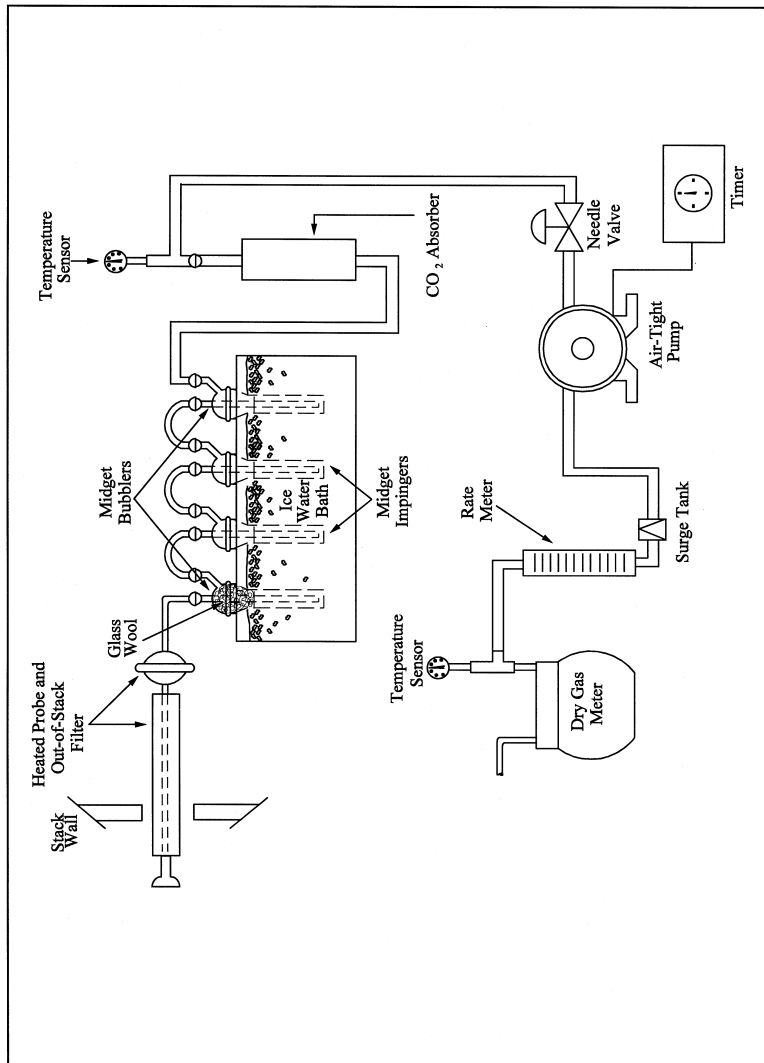

Figure 6A-1. Sampling train.

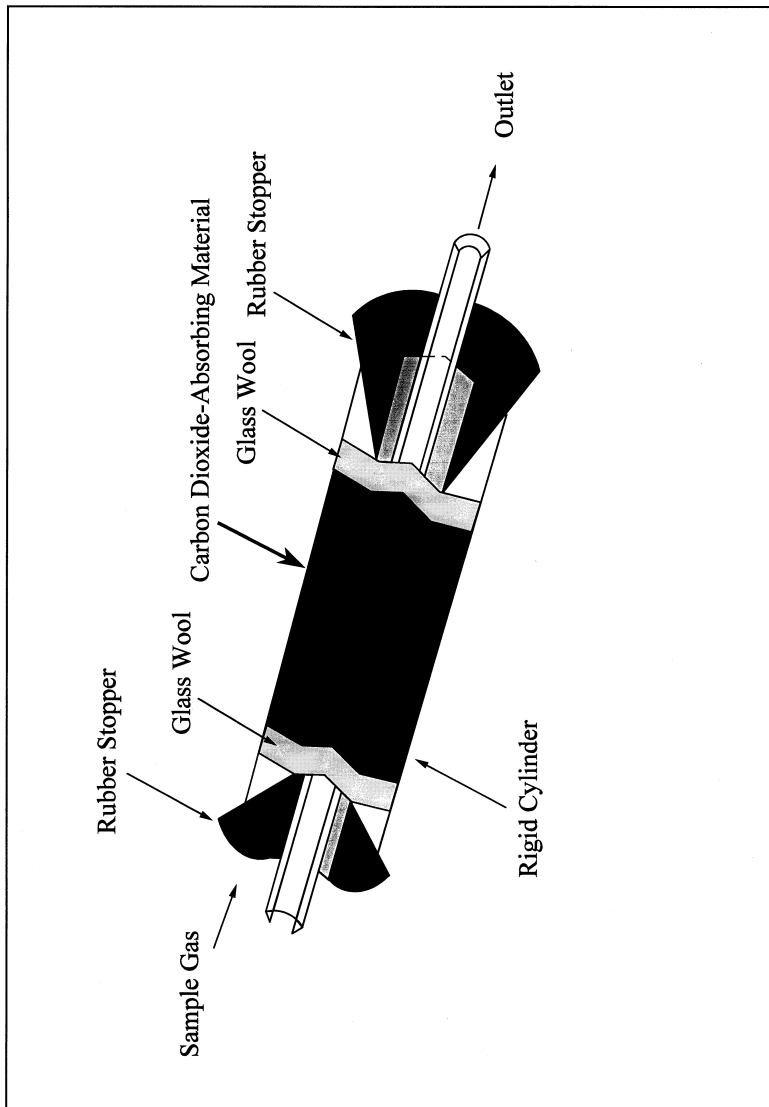

Figure 6A-2. CO₂ Absorber

METHOD 6B—DETERMINATION OF SULFUR DIOXIDE AND CARBON DIOXIDE DAILY AVERAGE EMISSIONS FROM FOSSIL FUEL COMBUSTION SOURCES

NOTE: This method does not include all of the specifications (e.g., equipment and supplies) and procedures (e.g., sampling and analytical) essential to its performance. Some material is incorporated by reference from

other methods in this part. Therefore, to obtain reliable results, persons using this method should have a thorough knowledge of at least the following additional test methods: Method 1, Method 2, Method 3, Method 5, Method 6, and Method 6A.

1.0 Scope and Application

1.1 Analytes.